

quorum

HANDHELD REMOTE CONTROL

Model: 7-501-0

INSTALLING RECEIVER IN CEILING FAN

A: Safety precautions:

- **WARNING: HIGH VOLTAGE!** Disconnect source of electrical power by removing fuse or switching off circuit breaker.
- Do not use with solid state fans.
- Electrical wiring must meet all local and national electrical code requirements.
- Electrical source and fan must be 115/120 volt, 60Hz. Maximum fan motor amps: 1.0. Maximum light watts: 300W Incandescent and Halogen.
- Household electrical power can cause serious injury or death!

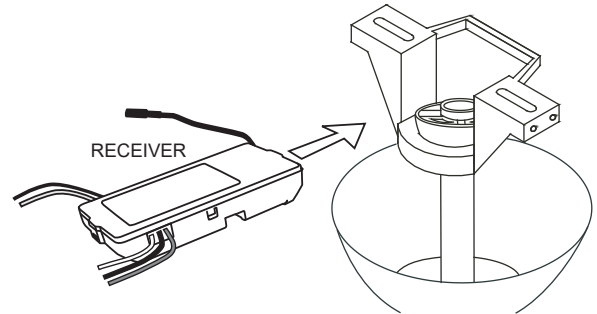

Fig. 1

B: Installing receiver in fan:

- Remove electrical power from the circuit.
- Disconnect existing wiring between ceiling fan and supply at electrical junction box.
- Lay the black antenna wire on top of the receiver, and put the receiver in the mounting bracket. (Fig. 1)
- Make connections as follows, using the wire nuts supplied (Fig. 2):

CONNECT	TO
Green fan wire.....	Bare supply wire
Black receiver wire (AC IN L).....	Black supply wire
White receiver wire (AC IN N).....	White supply wire
White receiver wire (TO MOTOR N).....	White fan wire
Black receiver wire (TO MOTOR L).....	Black fan wire
Blue receiver wire (FOR LIGHT).....	Blue light wire

If there are wires with different colors, have this unit installed by qualified licensed electrician.

- Push all connected wires up into junction box.
- Lay the black antenna wire on top of the receiver, and put the receiver in the mounting bracket. (Fig. 2)
- Reinstall all canopy on the mounting bracket

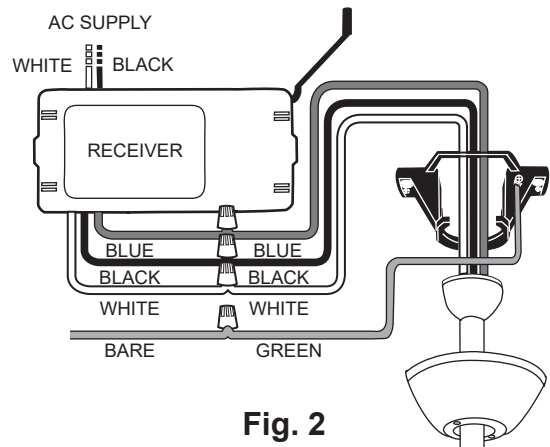

Fig. 2

C. Installing reverse module in ceiling fan

- Disconnect the switch cup assembly from the bottom of the fan. (If the fan is a new installation, this cup will not be attached to the fan yet)
- Connect the 'female' cannon plug on the reverse module to the cannon plug from the fan flange (Fig. 3)
- Connect the 'male' cannon plug on the reverse module to the cannon plug in the switch cup assembly.
- Secure the switch cup assembly to the fan as described in the fan installation instructions.

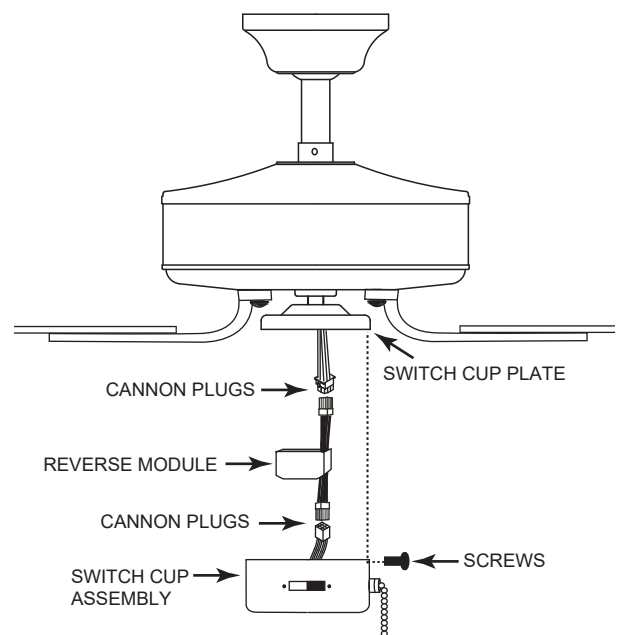

Fig. 3

D. Remote pairing process:

NOTE: This unit is equipped with an automatically learned type remote control. There are no frequency switches on the receiver and transmitter; the receiver unit will automatically scan the frequency from the handheld remote if any changes are made. This unit has 65,000 different code combinations.

Remove the set screw on the back of transmitter, take out the battery cover. Insert the 3 volt battery (included) and make sure they are seated correctly in each recess with the Positive + sign facing up. When remove or insert the batteries, use a suitable screwdriver to loosen or tighten the screws and open the back cover. (Fig. 4)

NOTE: To prevent damage to the transmitter, remove these batteries if not used for long periods of time (months).

With the fan's power off, restore power to the fan. Press and hold "■" button for about 5 seconds and release. If optional light kit is installed, the light kit will flash twice and the signal light on the handheld remote will come on when the button is pressed. The fan has completed the pairing process with the handheld remote and is ready for use.

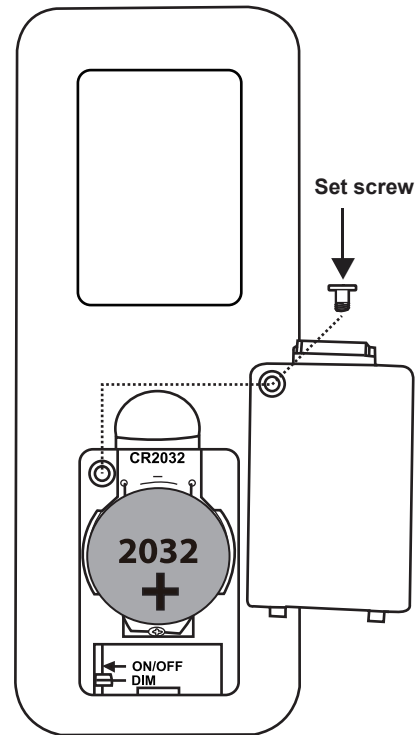

Fig. 4

OPERATING INSTRUCTIONS

A. H, M and L buttons: (Fig. 5)

These three buttons are used to set the fan speed as follows:

H= high speed

M= medium speed

L= low speed

B. ■ button:

This button turns the fan off.

C. The "☀" button:

The "☀" button turns the light ON or OFF and also controls the brightness setting. Press and hold the button to dim and brighten the light. Press and hold the button and release the button at desired brightness. The light key has an auto-resume, it will stay at the same brightness as the last time it was turned off.

D. The "↻" button is used to set the fan forward or reverse, press button forward (for warm weather) or reverse (for cool weather).

NOTE: To operate the reverse function on this fan, press the reverse button while the fan is running.

E. "2H", "4H" and "8H" buttons:

Pressing the timer buttons will automatically turn fan off after 2, 4, or 8 hours.

Please note that the timer buttons is active only when the fan speeds turn on. the light is not included.

You can cancel the timer by pressing ■ button and re-start the fan speed.

F. "DIM" and "ON/OFF" dip switch: (Fig. 4)

The "DIM" selection is the light dimmable selection and is to be used with LED bulbs only. The "ON/OFF" selection is the light on only (no dimmable function).

NOTE: The distance between the transmitter and receiver should not be greater than 30 feet. For best performance, make sure the Black Antenna on the end of the receiver unit remains extended and not tangled with any of the electrical wires.

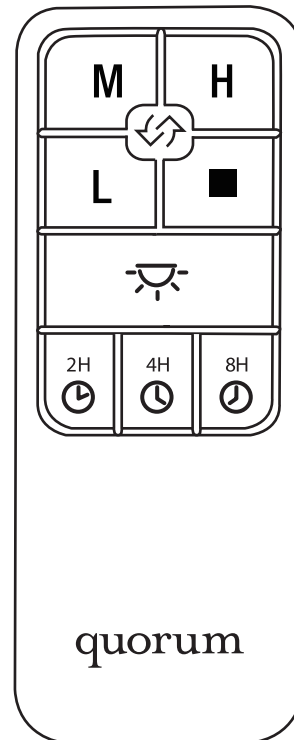

Fig. 5